	Tabella delle tolleranze (Scostamenti lineari) DIN ISO 2768		Scale : Varie	Creazione	Revisione - data	
	Da (mm)	A (mm)	Range (mm)	Materiale :	Data 02/07/2019 00 - 02/07/2019	
	0	30	Media +/- 0.1 Grossolana +/- 0.2	S 235 JR	Firma	
	30	120	Media +/- 0.3 Grossolana +/- 0.8	Modello / Componente :		
	120	400	Media +/- 0.5 Grossolana +/- 1.2	15_30T_Transenna 2.5m no rifr_Piede T-MI		
400	1000	Media +/- 0.8 Grossolana +/- 2	Codice :	Unità di misura :		
1000	2000	Media +/- 1.2 Grossolana +/- 3	15_30T	mm		
2000	4000	Media +/- 2 Grossolana +/- 4	Normativa :	Trattamento/Finitura :	Peso reale :	
				Zincatura a freddo	13.8 kg	
Via dell'artigianato, n°9 - 36070 Brogliano (VI) - Tel 0445-080001 Fax 0445-080002 www.mhitalia.it info@mhitalia.it						
E' vietata la riproduzione o comunicazione parziale o totale a terzi, senza autorizzazione scritta della ditta MH ITALIA SRL UNIPERSONALE						

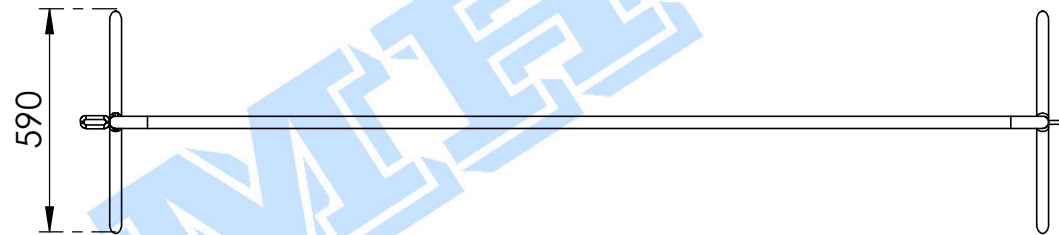

Tabella delle tolleranze (Scostamenti linife) DIN ISO 2768			Scale : Varie	Creazione	Revisione - data
Da (mm)	A (mm)	Range (mm)	Materiale :	Data	02/07/2019
0	30	Media +/- 0.1 Grossolana +/- 0.2	S 235 JR	Firma	00 - 02/07/2019
30	120	Media +/- 0.3 Grossolana +/- 0.8	Modello / Componente :		
120	400	Media +/- 0.5 Grossolana +/- 1.2	15_30U_Transenna 2.5m no rif_Piede U-MI		
400	1000	Media +/- 0.8 Grossolana +/- 2	Codice :	Unità di misura :	
1000	2000	Media +/- 1.2 Grossolana +/- 3	15_30U	mm	
2000	4000	Media +/- 2 Grossolana +/- 4	Normativa :	Trattamento/Finitura :	Peso reale :
			Zincatura a freddo		12.6 kg

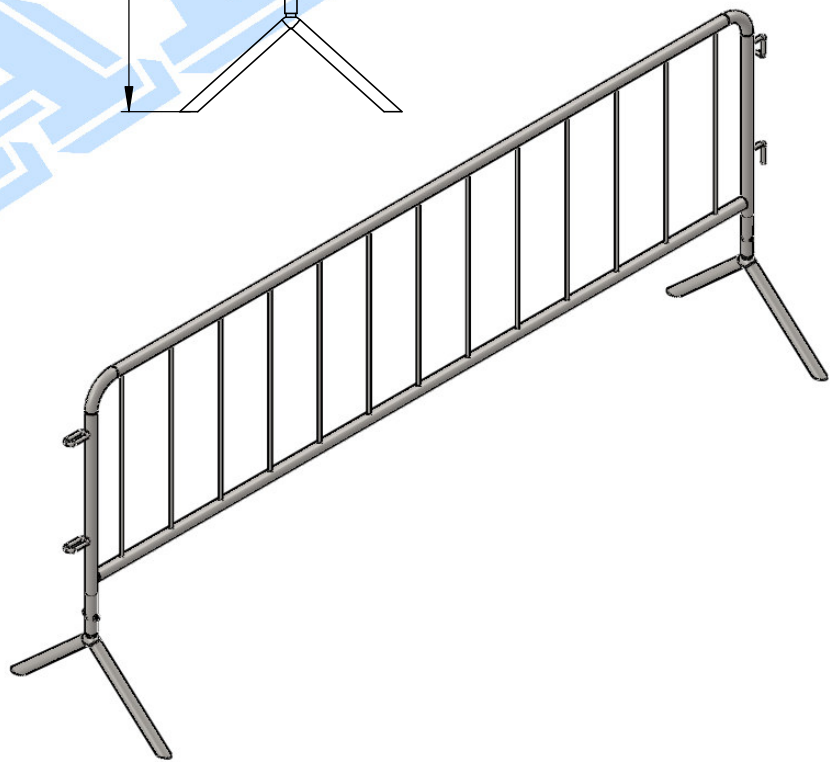
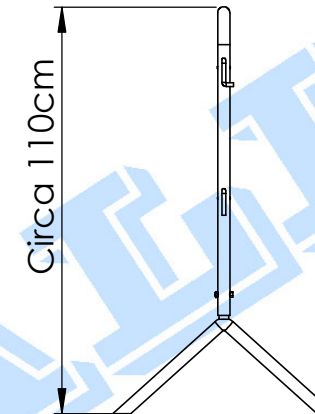
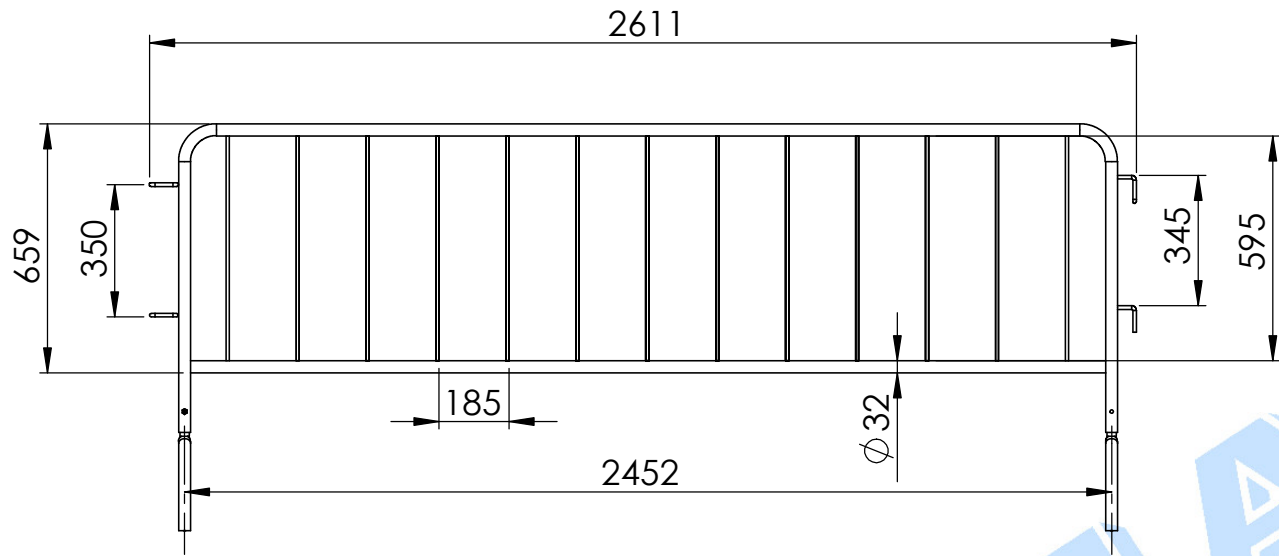

Via dell'artigianato, n°9 - 36070 Brogliano (VI) - Tel 0445-080001 Fax 0445-080002 www.mhitalia.it info@mhitalia.it

E' vietata la riproduzione o comunicazione parziale o totale a terzi, senza autorizzazione scritta della ditta **MH ITALIA SRL UNIPERSONALE**