	Tabella delle tolleranze (Scostamenti limife) DIN ISO 2768		Scale : Varie	Creazione	Revisione - data	
	Da (mm)	A (mm)	Range (mm)	Materiale :	Data 30/05/2019	
	0	30	Media +/- 0.1 Grossolana +/- 0.2	S 235 JR	Firma	00 - 30/05/2019
	30	120	Media +/- 0.3 Grossolana +/- 0.8	Modello / Componente :		Int max: cm
	120	400	Media +/- 0.5 Grossolana +/- 1.2	100800_Staffa a perdere 300		
	400	1000	Media +/- 0.8 Grossolana +/- 2	Codice :	Unità di misura :	
1000	2000	Media +/- 1.2 Grossolana +/- 3	100800	mm		
2000	4000	Media +/- 2 Grossolana +/- 4	Normativa :	Trattamento/Finitura :	Peso :	
			UNI EN 13374	Zincatura a freddo	0.27 kg	
Via dell'artigianato, n°9 - 36070 Brogliano (VI) - Tel 0445-080001 Fax 0445-080002 www.mhitalia.it info@mhitalia.it						
E' vietata la riproduzione o comunicazione parziale o totale a terzi, senza autorizzazione scritta della ditta MH ITALIA SRL UNIPERSONALE						

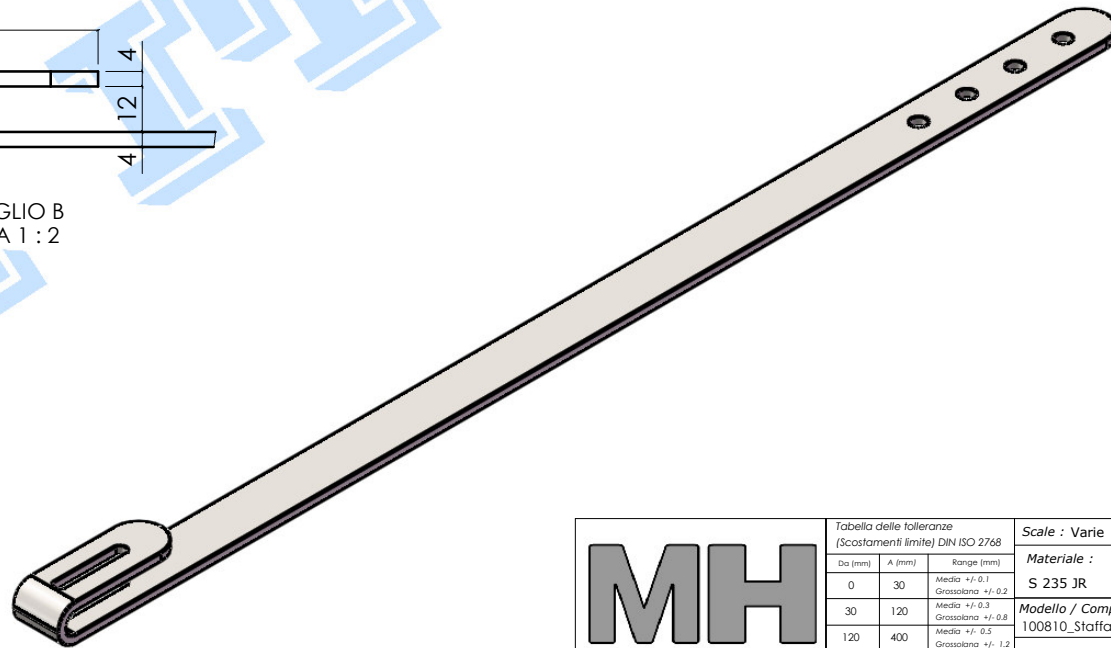

	Tabella delle tolleranze (Scostamenti limife) DIN ISO 2768		Scale : Varie	Creazione	Revisione - data	
	Da (mm)	A (mm)	Range (mm)	Materiale :	Data 30/05/2019 00 - 30/05/2019	
	0	30	Media +/- 0.1 Grossolana +/- 0.2	S 235 JR	Firma	
	30	120	Media +/- 0.3 Grossolana +/- 0.8	Modello / Componente : 100810_Staffa a perdere 600 Int max: cm		
	120	400	Media +/- 0.5 Grossolana +/- 1.2	Codice : 100810	Unità di misura : mm	
400	1000	Media +/- 0.8 Grossolana +/- 2	Normativa : UNI EN 13374		Trattamento/Finitura : Zincatura a freddo	
1000	2000	Media +/- 1.2 Grossolana +/- 3			Peso : 0.50 kg	
2000	4000	Media +/- 2 Grossolana +/- 4				
Via dell'artigianato, n°9 - 36070 Brogliano (VI) - Tel 0445-080001 Fax 0445-080002 www.mhitalia.it info@mhitalia.it						
E' vietata la riproduzione o comunicazione parziale o totale a terzi, senza autorizzazione scritta della ditta MH ITALIA SRL UNIPERSONALE						

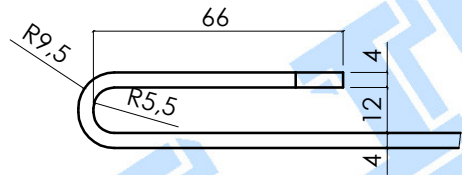
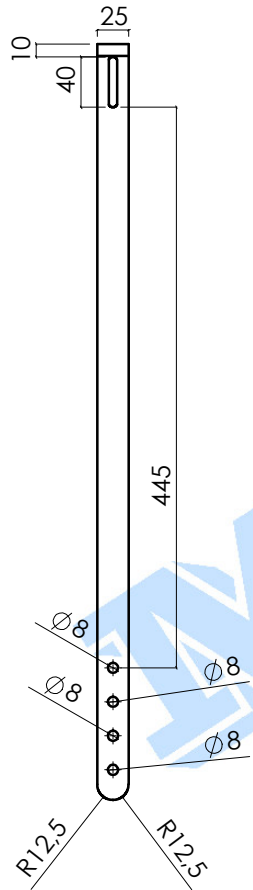
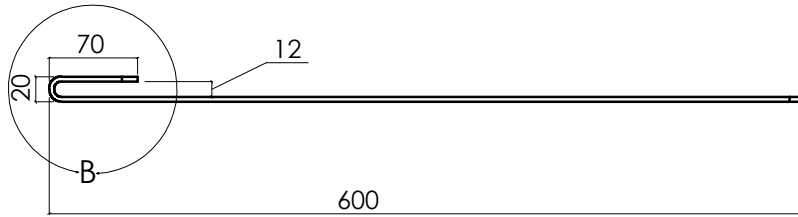
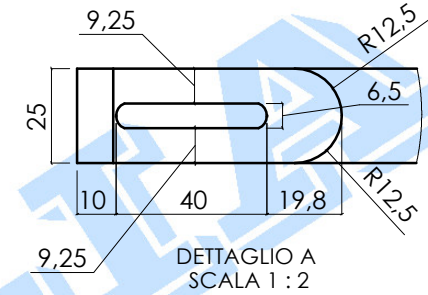
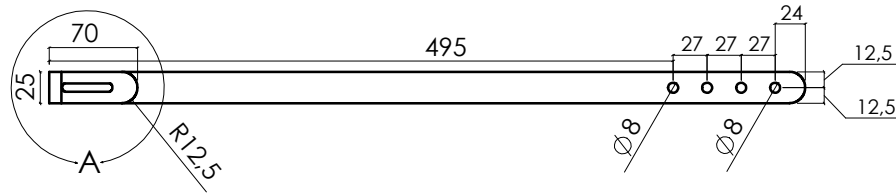
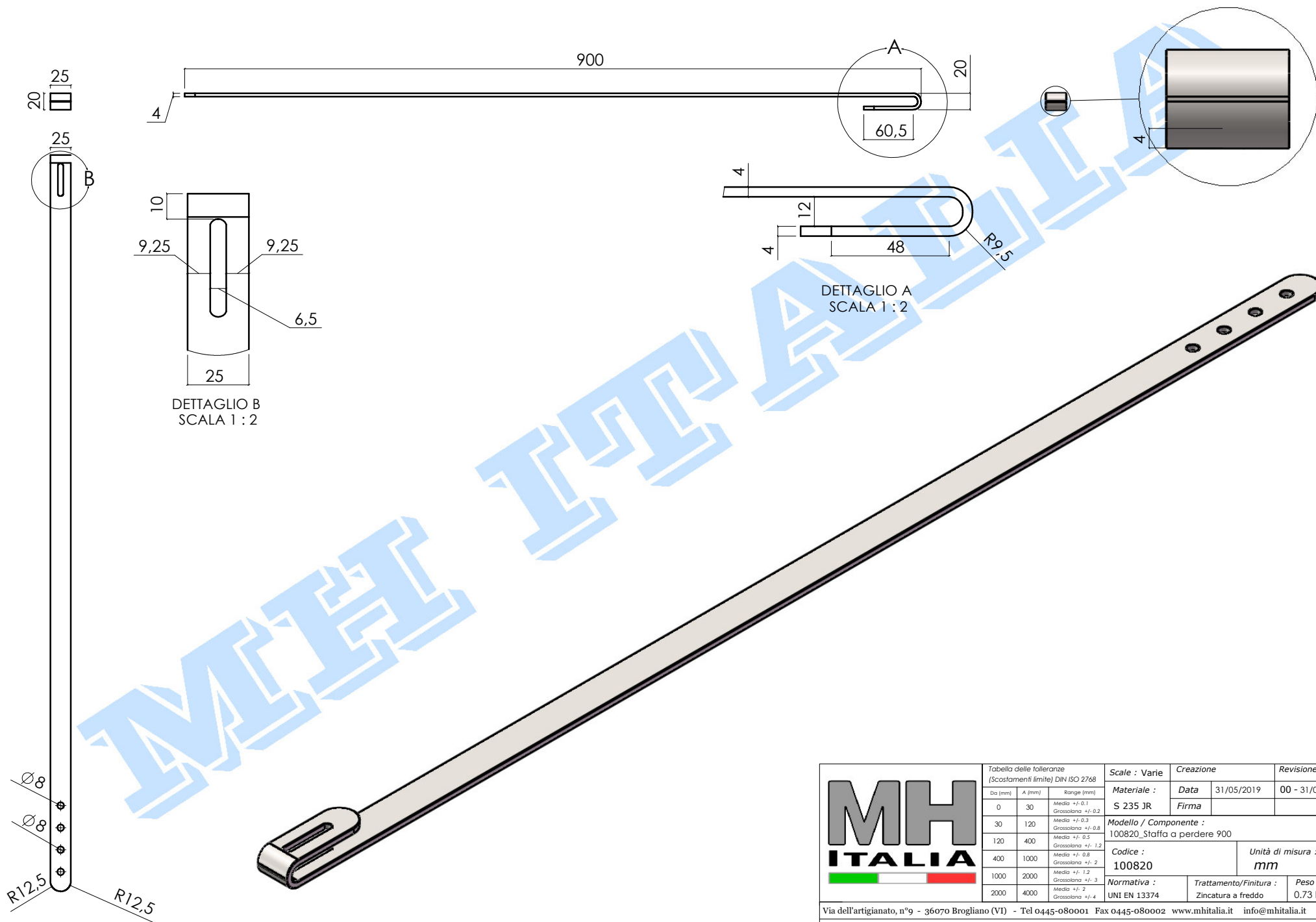

	Tabella delle tolleranze (Scostamenti lineari) DIN ISO 2768		Scale : Varie	Creazione	Revisione - data
	Da (mm)	A (mm)	Range (mm)	Materiale : S 235 JR	Data 31/05/2019
	0	30	Media +/- 0.1 Grossolana +/- 0.2	Firma	00 - 31/05/2019
	30	120	Media +/- 0.3 Grossolana +/- 0.8	Modello / Componente : 100820_Staffa a perdere 900	
	120	400	Media +/- 0.5 Grossolana +/- 1.2	Codice : 100820	Unità di misura : mm
	400	1000	Media +/- 0.8 Grossolana +/- 2	Normativa : UNI EN 13374	Trattamento/Finitura : Zincatura a freddo
1000	2000	Media +/- 1.2 Grossolana +/- 3		Peso : 0.73 kg	
2000	4000	Media +/- 2 Grossolana +/- 4			

Via dell'artigianato, n°9 - 36070 Brogliano (VI) - Tel 0445-080001 Fax 0445-080002 www.mhitalia.it info@mhitalia.it
 E' vietata la riproduzione o comunicazione parziale o totale a terzi, senza autorizzazione scritta della ditta **MH ITALIA SRL UNIPERSONALE**